

Verification of Intelligent Controllers using Model Checking

Charles Pecheur, UC Louvain



(formerly RIACS / NASA Ames)



Embedded Controllers

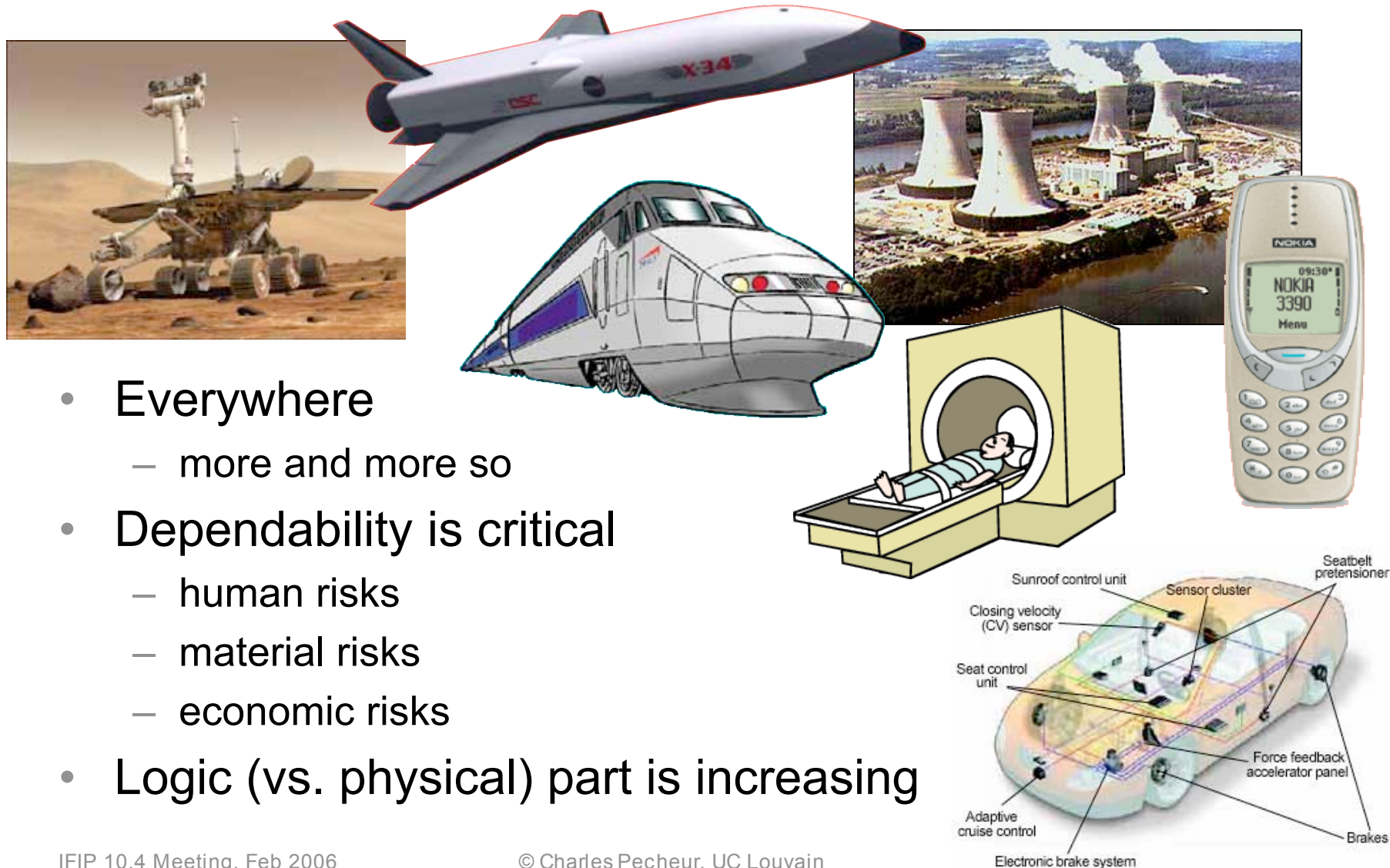

- Everywhere
 - more and more so
- Dependability is critical
 - human risks
 - material risks
 - economic risks
- Logic (vs. physical) part is increasing

Process Control

- **Partially observable** process (hidden state \mathbf{x} , estimated by $\hat{\mathbf{x}}$)
- **observability** : infer \mathbf{x} from \mathbf{y} (and \mathbf{u})
- **commandability** : impose \mathbf{x} through \mathbf{u}
- **control theory** : \mathbf{x} = physical quantities, differentiable
→ linear models, PDI controllers
- **logic processes** : \mathbf{x} = states, modes, **failures**, discrete
→ state machines, programmable automata

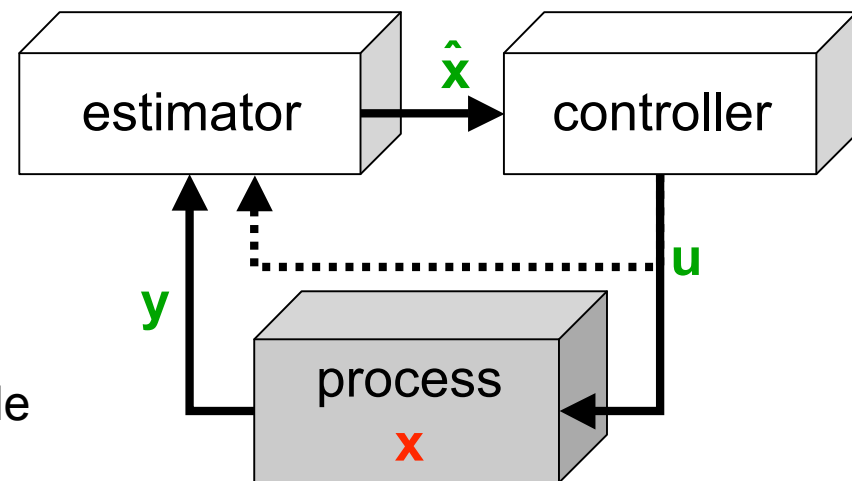

Verification of Control Systems

- **Monitors** and **commands** a process
 - in particular, **failure diagnosis** and **recovery**
- **Complex**
 - multiple controllers, asynchronism, coupling
 - race conditions, feature interaction
- **Software**
 - powerful and flexible but not linear, not continuous
- **How to Validate ?**
 - including "**diagnosability**" and "**recoverability**" from failures ?

Reliability: Hardware vs Software

Hardware	Software
physical variability	identical copies
failures due to wear, environment	design flaws
reliability through redundancy	copies of the same code have the same bugs
reliability varies in time	reliability depends on execution, not on time
progressive degradation	abrupt degradation

Autonomy (at NASA)

Autonomous spacecraft = on-board intelligence (AI)

- **Goal:** Unattended operation in an unpredictable environment
- **Approach:** **model-based reasoning**
- **Pros:** smaller mission control crews, no communication delays/blackouts
- **Cons:** **Verification and Validation ???**
Much more complex, huge state space
- **Better verification is critical for adoption**

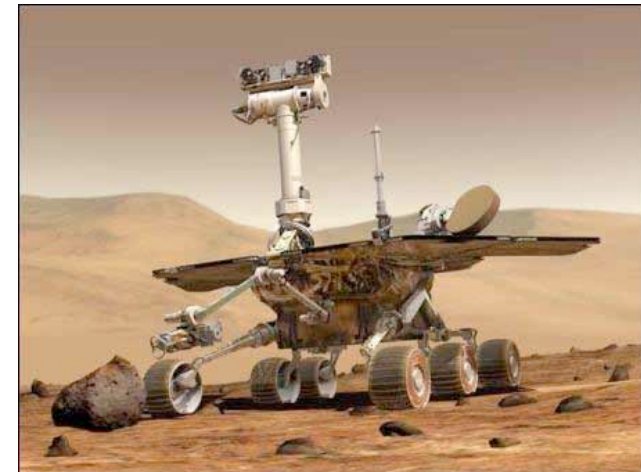

Model-Based Autonomy

- Based on AI technology
- Generic **reasoning engine** + application-specific **model**
- Model describes (normal and faulty) behaviour of the process
- Engine selects control actions "on-the-fly" based on the model
 - ... rather than pre-coded decision rules
 - better able to respond to unanticipated situations

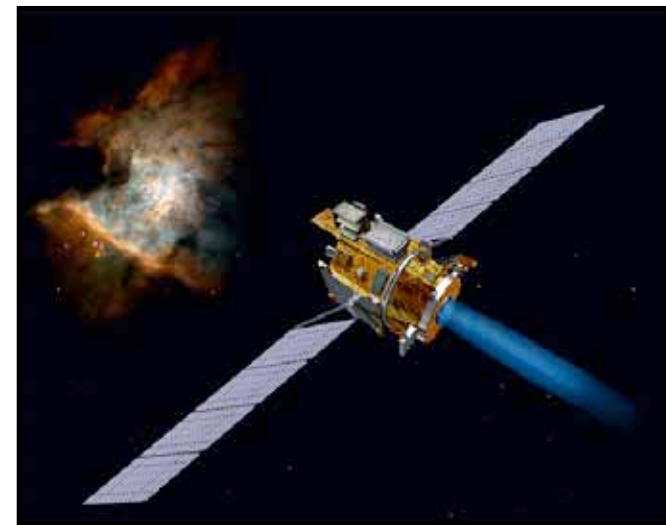
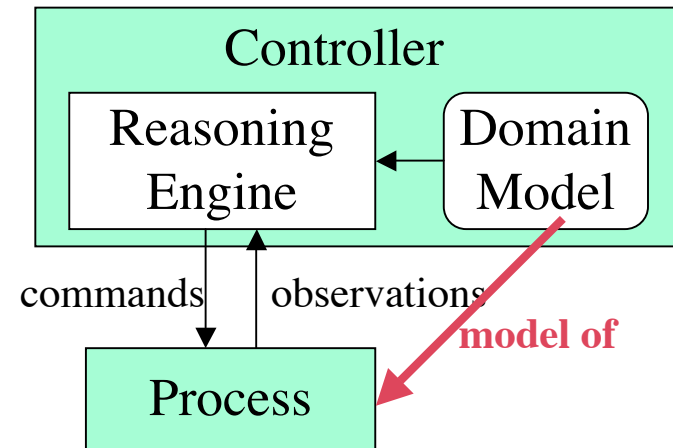

Livingstone

- **Model-based diagnosis system** from NASA Ames
 - i.e. an advanced state estimator
- Uses a discrete, qualitative model to reason about faults
 - => naturally amenable to formal analysis

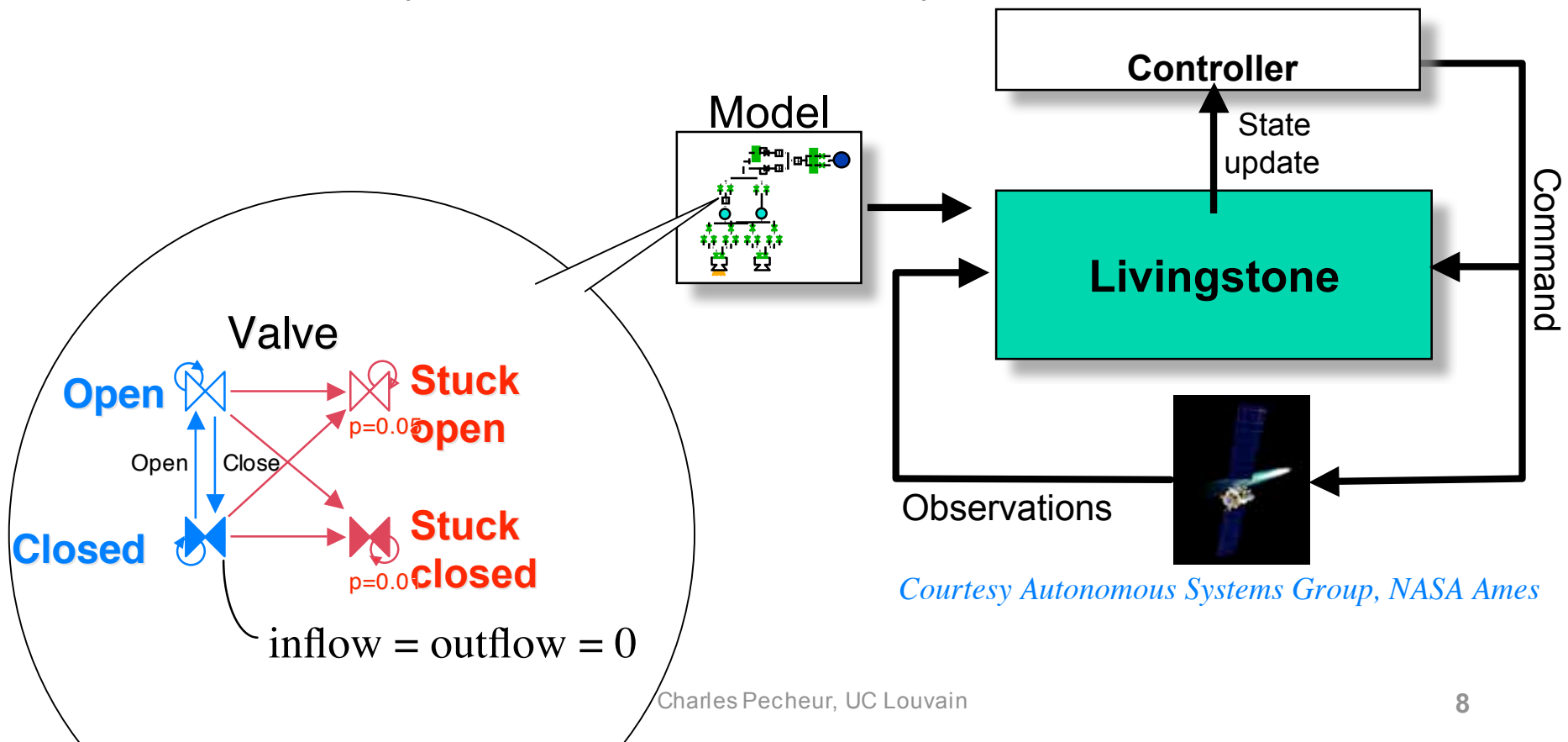

Courtesy Autonomous Systems Group, NASA Ames

A Simple Livingstone Model

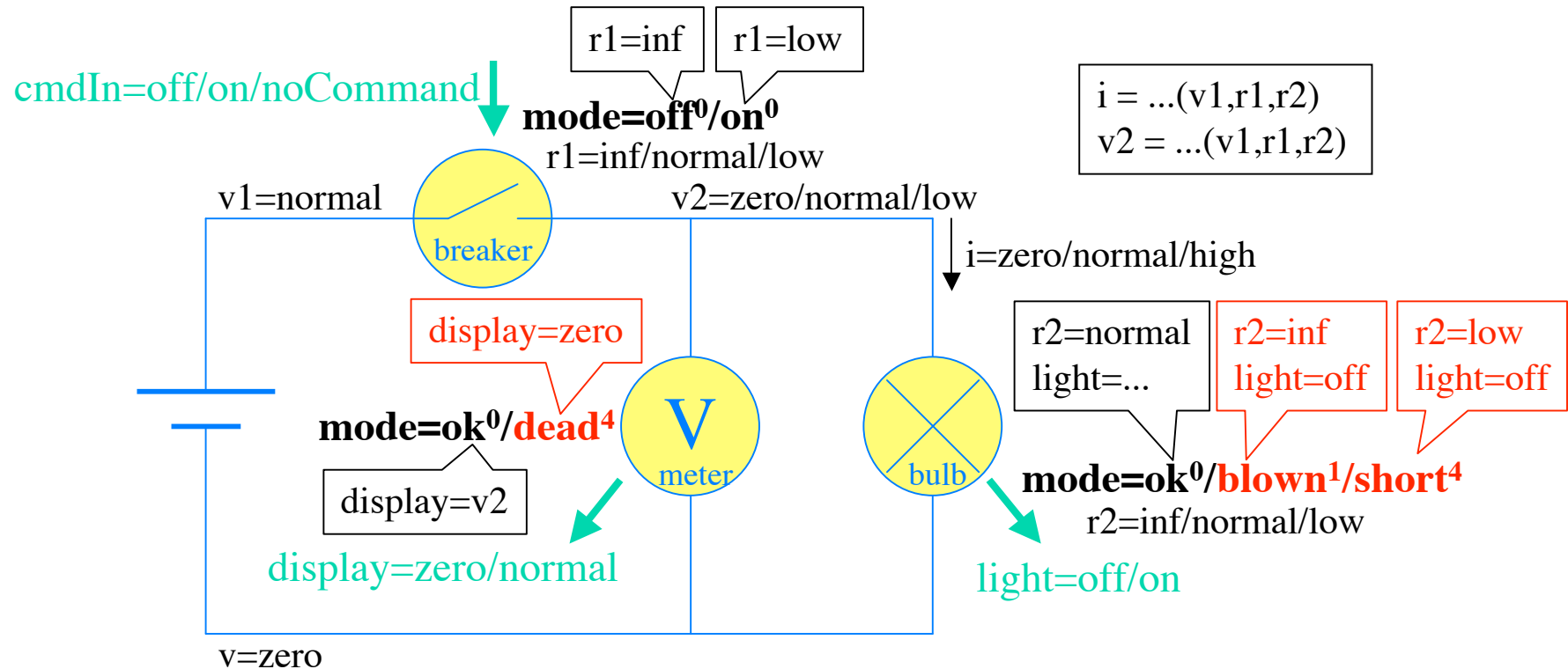

i = ...(v1,r1,r2)
v2 = ...(v1,r1,r2)

Goal: determine **modes** from **observations**
Generates and tracks *candidates*

breaker	bulb	meter	rank
off ⁰	ok ⁰	ok ⁰	0
off ⁰	ok ⁰	blown ¹	1
on ⁰	dead ⁴	short ⁴	8

Verify Model-Based Control?

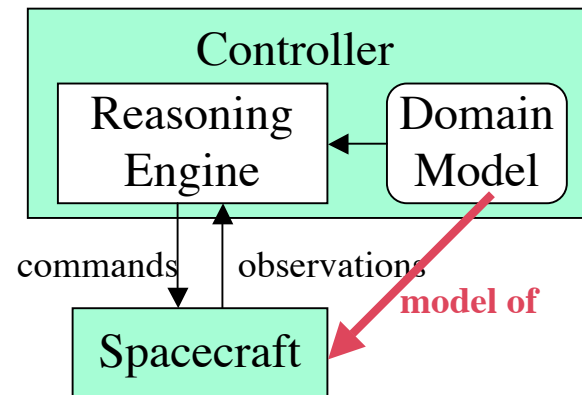

Of course, but what exactly?

- The model?
- The engine?
- The whole controller?
- **All of the above!**

Verification of the Model

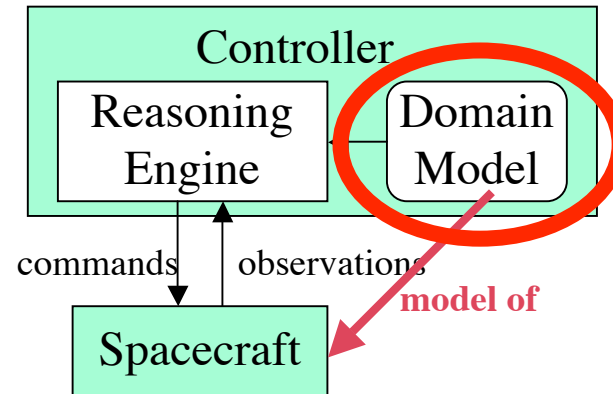

- This is the "application code"
 - where the development effort (and bugs) are
- Abstract, concise, amenable to formal analysis
 - this is another benefit of model-based approaches
 - ... or model-based design in general

Model Checking

- **Model checking** = (ideally) **exhaustive** exploration of the (finite) state space of a system
 - \approx exhaustive testing with loop / join detection

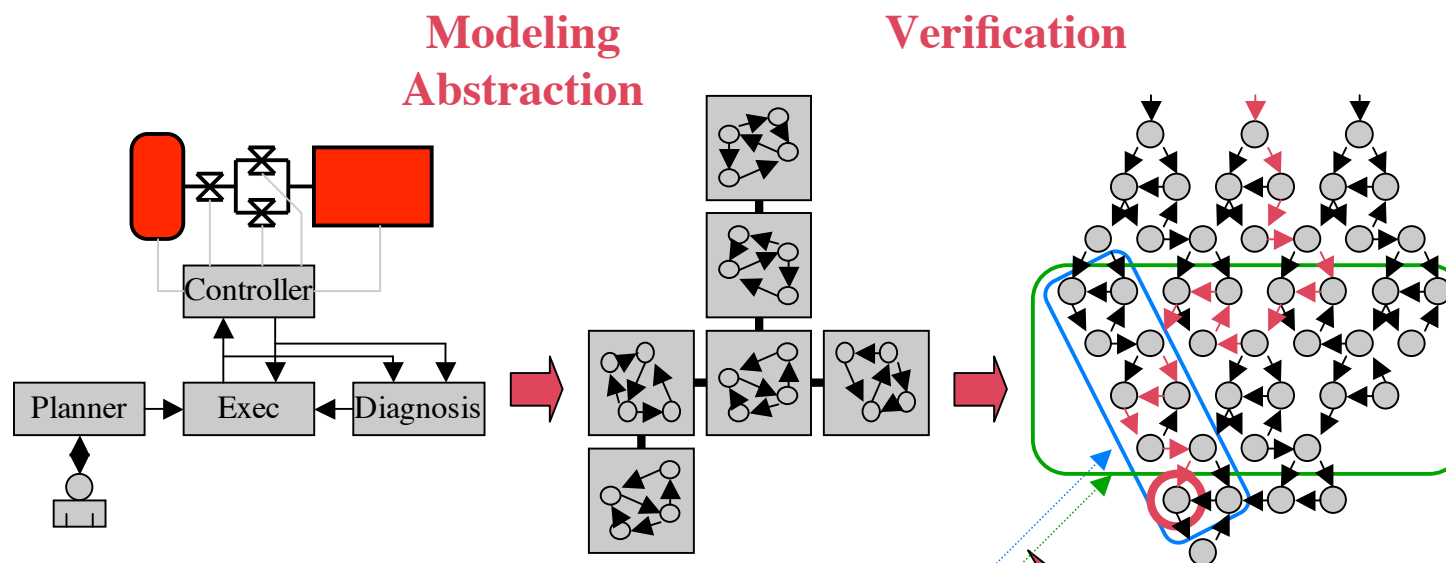

“Valve is closed when Tank is empty”

AG (tank=empty \Rightarrow valve=closed)

Symbolic Model Checking

- **Symbolic** model checking =
 - compute **sets of states**,
 - using **symbolic representations**,
 - that can be **efficiently encoded and computed**.

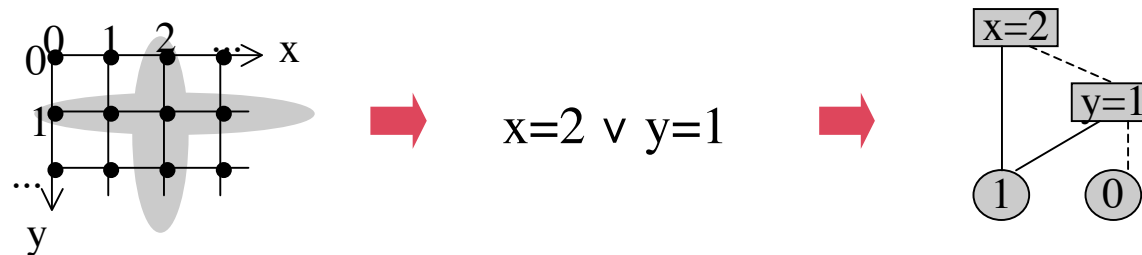

- Can handle **very large state spaces** (10^{50+}), or even **infinite domains** (continuous time and variables)
- Example: **SMV/NuSMV** (Carnegie Mellon/IRST)
 - finite state using boolean encoding (BDD, SAT)

Livingstone-to-SMV Translator

Joint work with Reid Simmons (Carnegie Mellon)

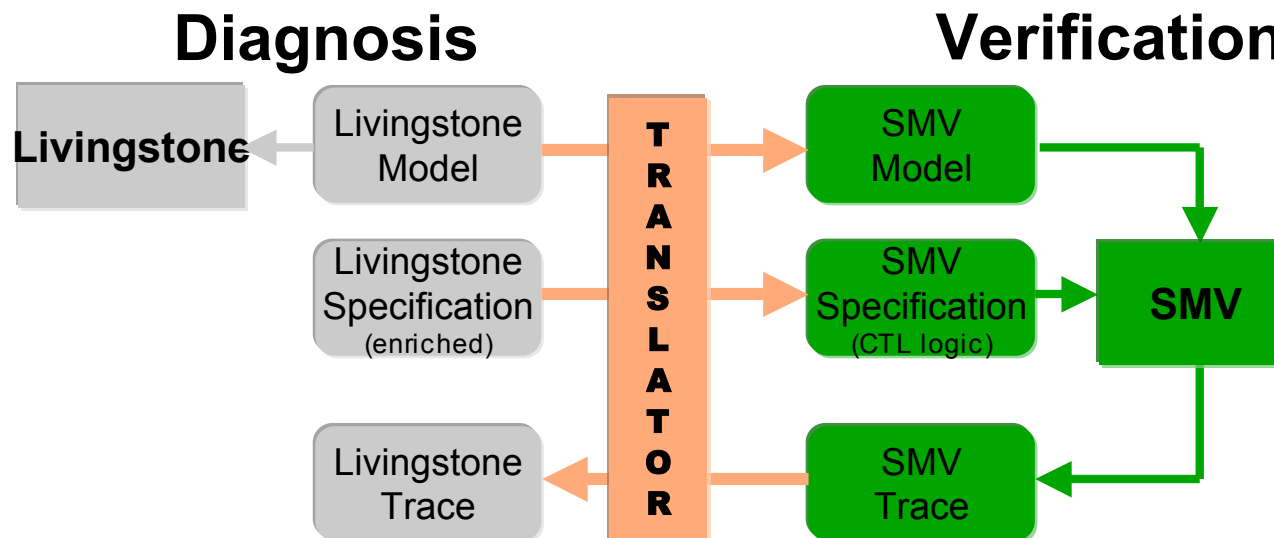

- A translator that converts Livingstone models, specs, traces to/from SMV (in Java)
 - SMV: symbolic model checker (both BDD and SAT-based) allows exhaustive analysis of very large state spaces (10^{50+}) ⇒
- Hides away SMV, offers a **model checker for Livingstone**
- Enriched specification syntax (vs. SMV's core temporal logic)
- Graphical interface, integration in Livingstone development tools

Verification of Diagnosis Models

- Coding Errors
 - e.g. Consistency, well-defined transitions, ...
 - Generic
 - Compare to Lint for C
- Model Correctness
 - Expected properties of modeled system
 - e.g. flow conservation, operational scenarios, ...
 - Application-specific
- **Diagnosability**
 - Are faults detectable/diagnosable?
 - Given available sensors
 - In all/specific operational situations (dynamic)

Diagnosability

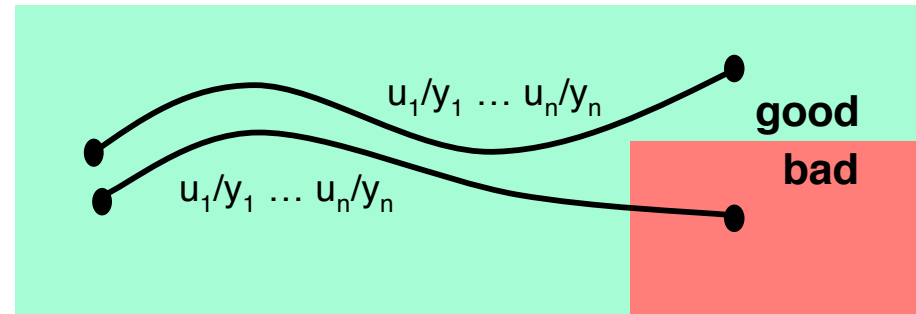
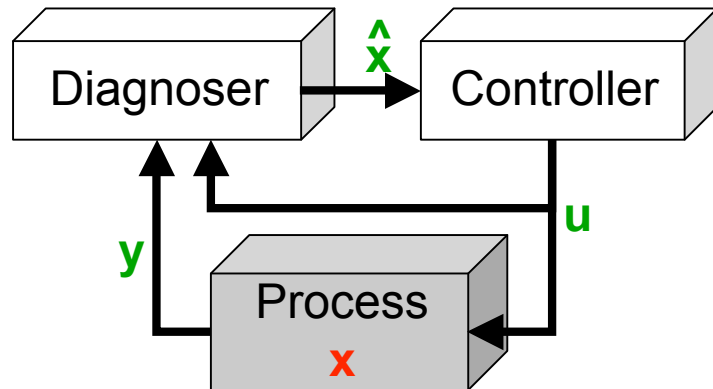

- **Diagnosis:** estimate the hidden state x (incl. failures) given observable commands u and sensors y .
- **Diagnosability:** Can (a smart enough) *Diagnoser* always tell when *Process* comes to a **bad** state?
- **Property of the Process** (not the Diagnoser)
 - even for non-model-based diagnosers
 - but analysis needs a (process) model

Verification of Diagnosability

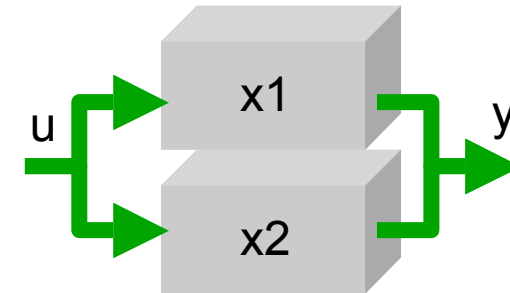
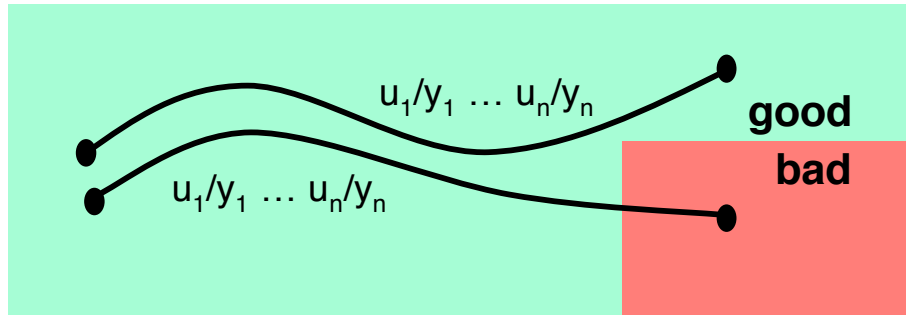

- **Intuition:** **bad** is diagnosable if and only if there is no pair of trajectories, one reaching a **bad** state, the other reaching a **good** state, with identical observations.
 - or some generalization of that: (context, two different faults, ...)
- **Principle:**
 - consider two concurrent copies $x1$, $x2$ of the process, with coupled inputs u and outputs y
 - check for reachability of (**good**($x1$) && **bad**($x2$))
- Back to a classical (symbolic) model checking problem !
- Supported by Livingstone-to-SMV translator

In-Situ Propellant Production

- Use atmosphere from Mars to make fuel for return flight.
- Livingstone controller developed at NASA KSC.
- Components are tanks, reactors, valves, sensors...
- Exposed improper flow modeling.
- Latest model is 10^{50} states.

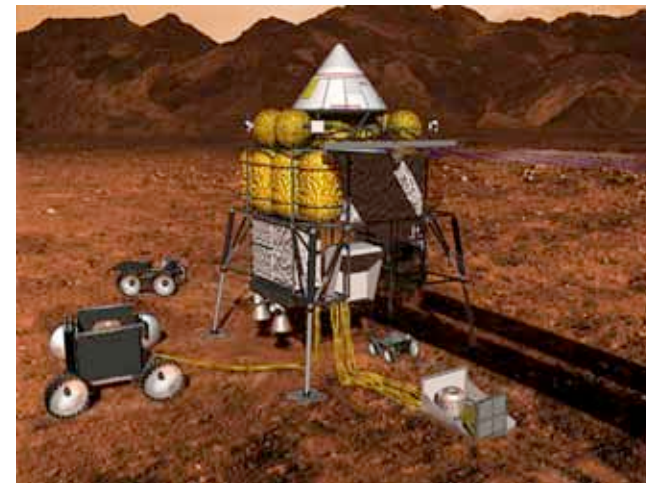
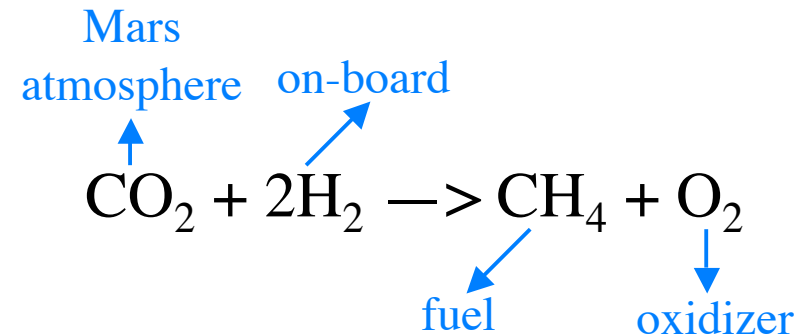

X-34 / PITEX

- Propulsion IVHM Technology Experiment (ARC, GRC)
- Livingstone applied to propulsion feed system of space vehicle
- Livingstone model is $4 \cdot 10^{33}$ states

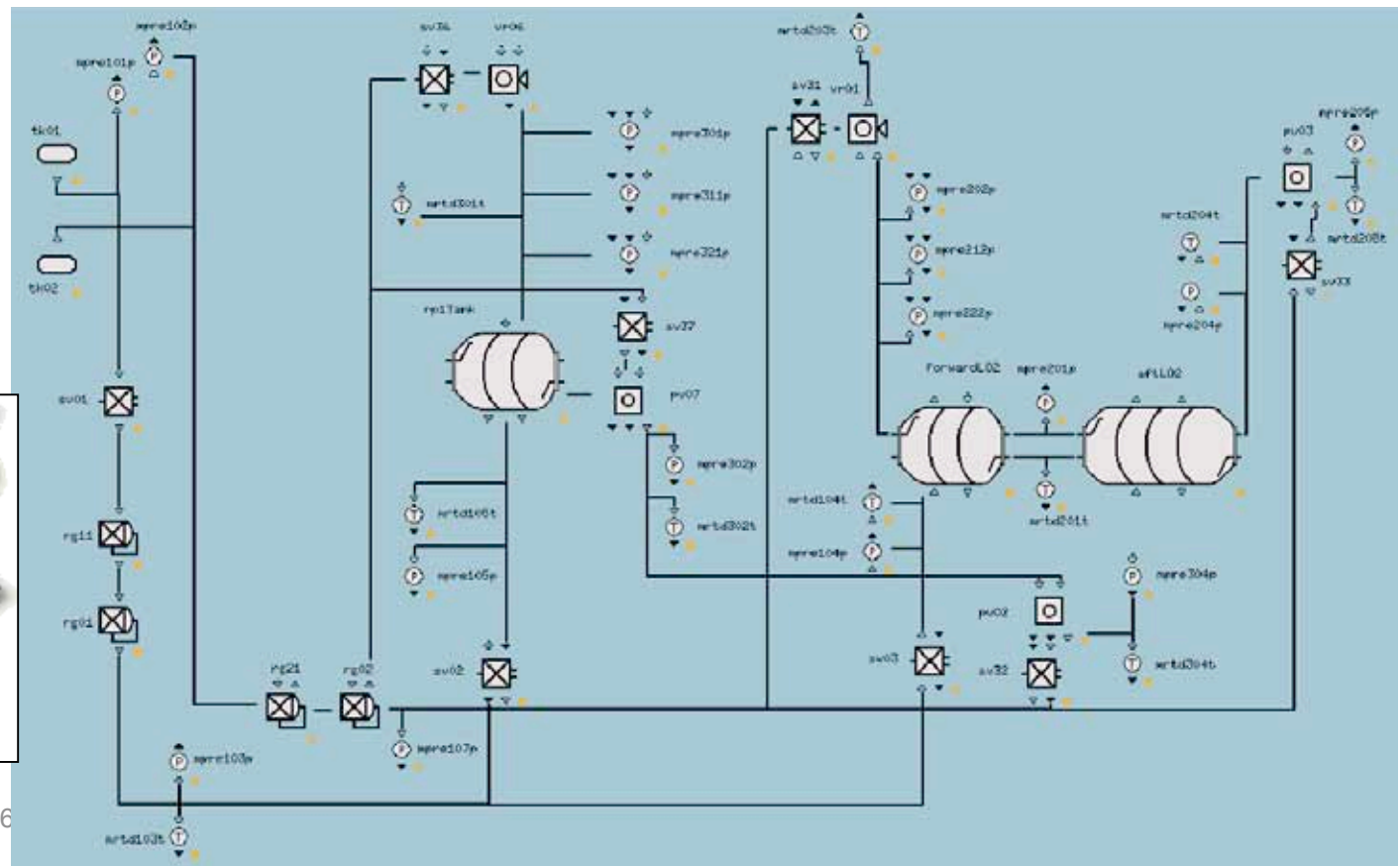

PITEX Diagnosability Error

with Roberto Cavada (IRST, NuSMV developer)

- "Diagnosis can decide whether the venting valve VR01 is closed or stuck open (assuming no other failures)"

INVAR !test.multibroken() & twin(!test.broken())

VERIFY INVARIANT !(test.vr01.mode=stuckOpen & twin(test.vr01.valvePosition=closed))

- Results show a pair of traces with same observations, one leading to **VR01 stuck open**, the other to **VR01 closed**. Application specialists fixed their model.

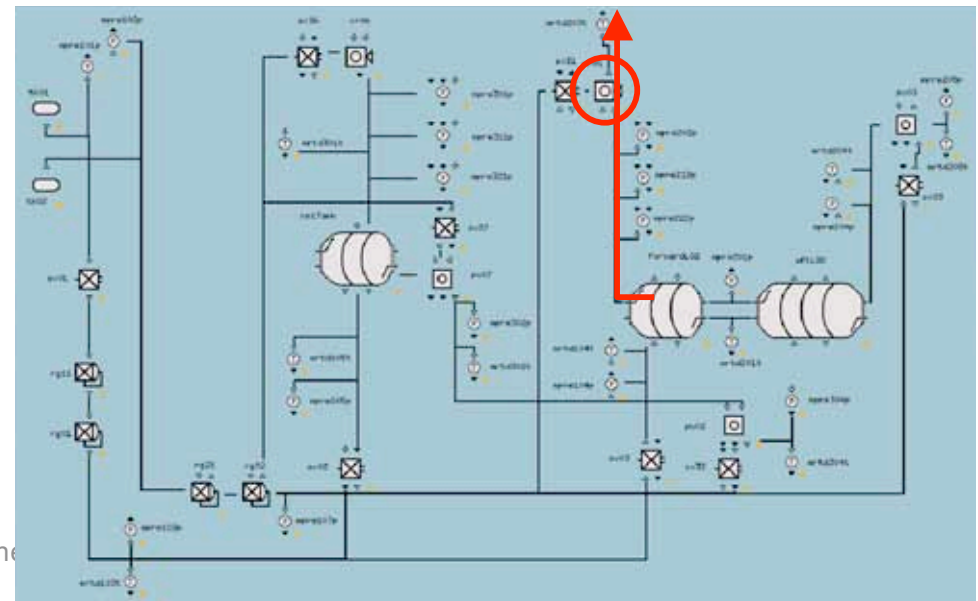

Verification of the Controller

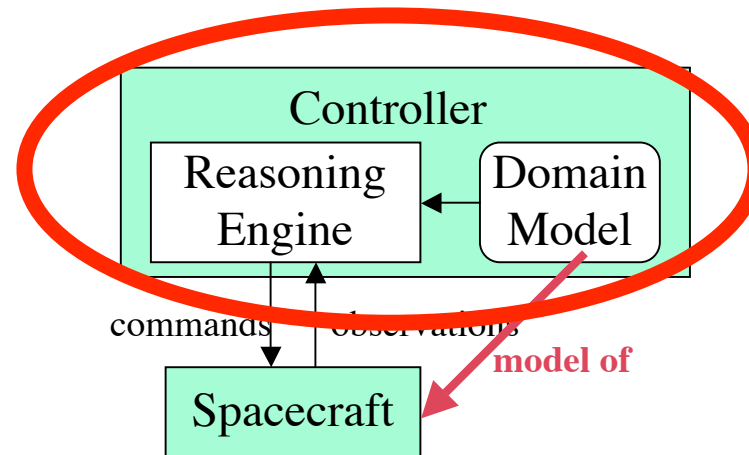

- good model + good engine \neq good controller
 - Heuristics in engine, simplifications in model
- System-level verification
 - Controller as black (or grey) box
 - Need a model of the environment (test harness)
 - Applicable to others than model-based

Livingstone PathFinder

with Tony Lindsey (QSS @ ARC)

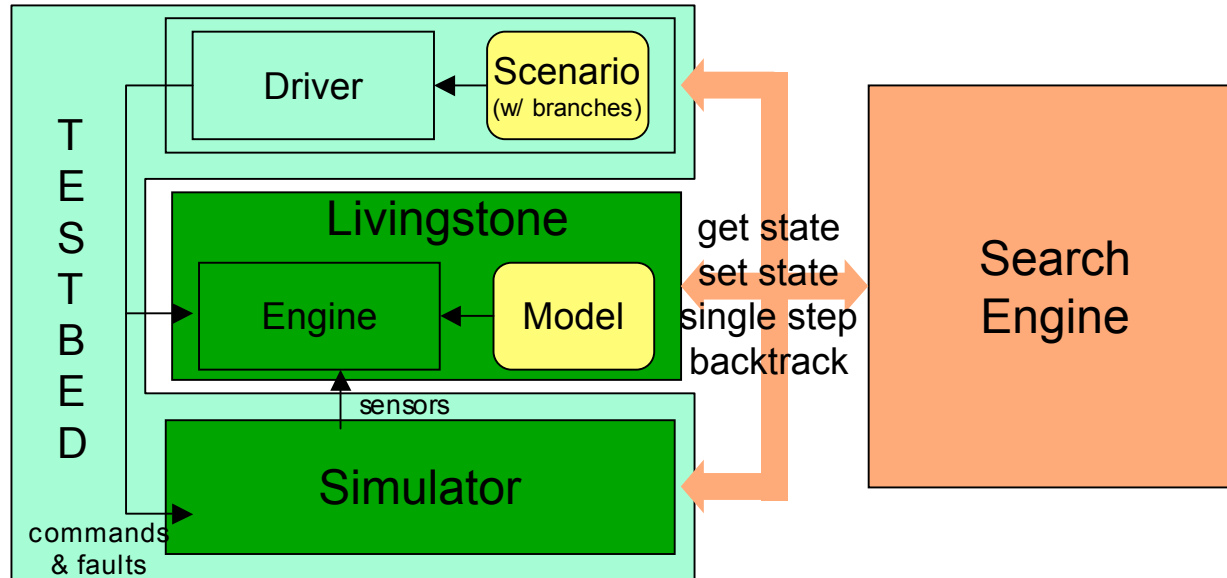

- An advanced testing/simulation framework for Livingstone applications
 - Executes the **Real Livingstone Program** in a simulated environment (testbed)
 - **Instrument** the code to be able to **backtrack** between alternate paths
- **Scenarios** = non-deterministic test cases (defined in custom language)
- **Modular** architecture with generic APIs (in Java)
 - allows different diagnosers, simulators (can use Livingstone), search algorithms (depth-first, breadth-first, heuristic, random, ...)
- See TACAS'04 paper

Verification of the Engine

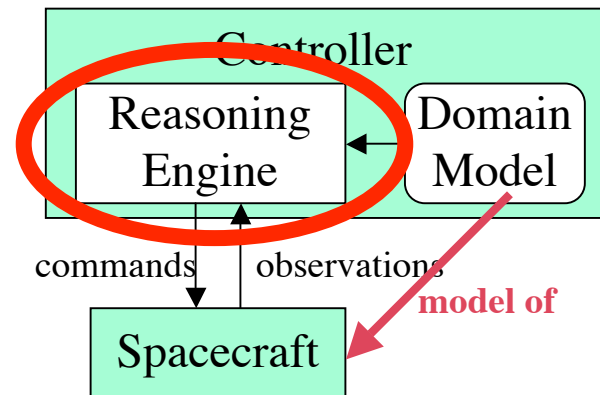

- A (technically complex) computer program
 - Use traditional software verification approaches
 - Maybe full-blown proof on core algorithms
- Generic, re-used across applications
 - More likely to be stable and trustable
 - Like compilers, interpreters, virtual machines, etc

... and Verification of Software

- There is more to it than reasoning engines!
 - Device drivers, OS, navigation, communication, ...
 - real-time, **concurrent**, reactive, interrupts, priorities, ...
- All traditional good practices apply
 - **Sound software engineering practices** (requirements, design, modelling, documentation, reviews, testing, configuration management, ...)
 - Advanced software verification techniques (monitoring, static analysis, model checking, proofs)

The Program Verification Spectrum

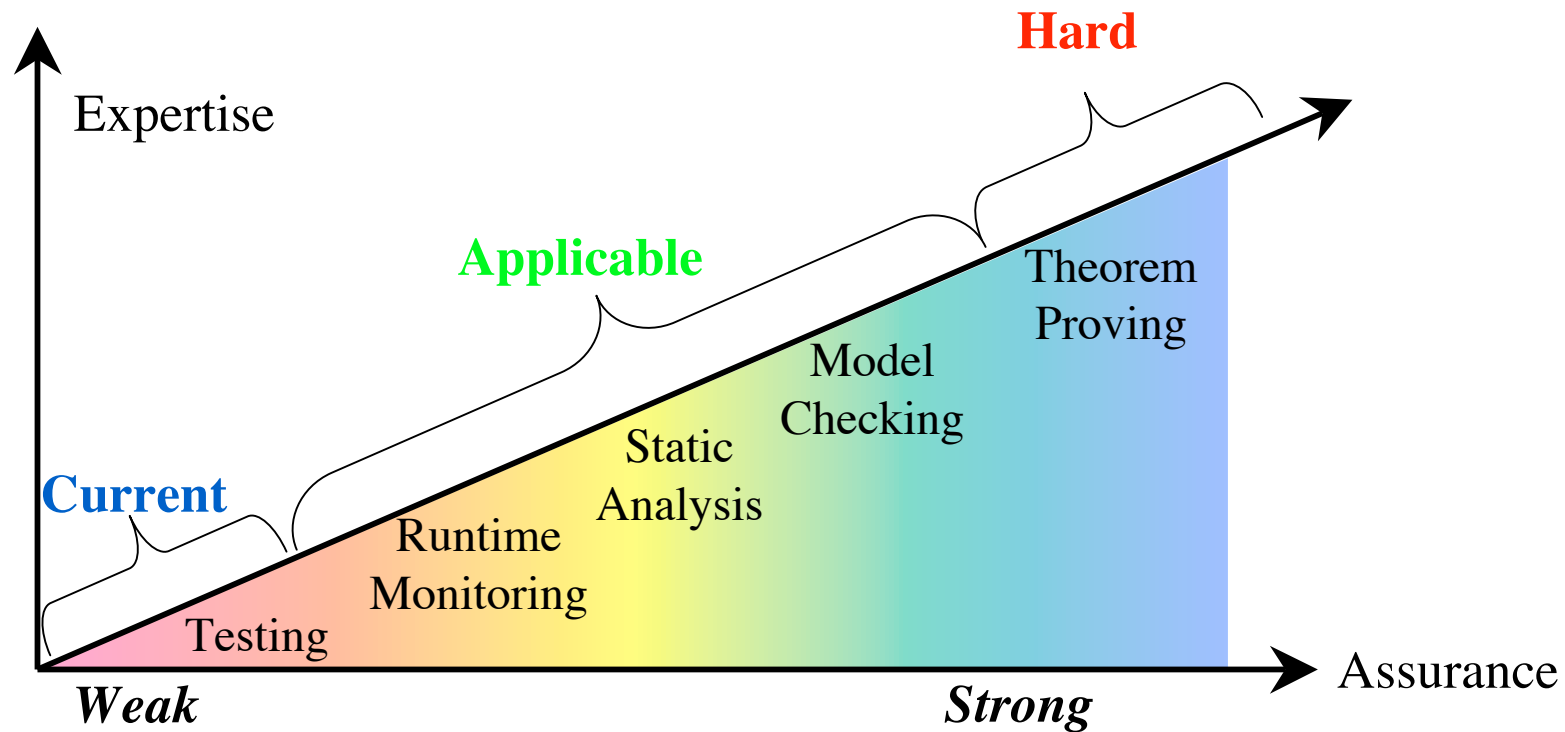

(adapted from John Rushby)

Software Failure Example 1

Ariane 501 (1996)

- **cause** : fixpoint arithmetic overflow in guidance system
- **effect** : rocket and payload destroyed, program delayed
- **solution** : static analysis to detect potential runtime errors
 - This was the driving target for developing PolySpace



Software Failure Example 2

Mars Climate Orbiter (1999)

- **cause** : US/metric unit incompatibility between components
- **effect** : incorrect orbit insertion trajectory, probe crashed (and public embarrassment)
- **solution** : strong type checking, rigorous design practices



Software Failure Example 3

Remote Agent Experiment (1999)

- **cause** : missing critical section in concurrent program
- **effect** : race condition and deadlock in flight
 - in supervised experiment, no mission damage
- **solution** : model checking
 - a similar bug was found before flight using SPIN on another part of the code



Human Factors

- Adapt technology to its users
 - use their paradigms/languages (translation)
 - integrate in their tools and environments
 - vision : verification tools as advanced debuggers
- Technology maturation
 - From something that works to something that is usable
 - Lots of work and time
 - Polish the code but also documentation, training, etc
- Space mission adoption
 - Space missions take very conservative attitude w.r.t. new technologies (for good reason)
 - No-one wants to be the first adopter
 - Usefulness of technology validation missions

Conclusions

- Verification of **control software**
 - Particularity : control loop, observability/commandability
 - In particular, failure diagnosability and recoverability
- Verification of **model-based controllers**
 - **Needs** advanced verification (because of large state space)
 - **Facilitates** advanced verification (thanks to model)
- **Model checking**
 - Applicable to these problems
 - esp. symbolic model checking, esp. to model-based
 - Delicate precision/scalability trade-off
- Verification of **software**
 - All other principles still apply

Perspectives

- Key ideas:
 - **model-based analysis (model checking)**
 - **partial observability**
- Extensions
 - from discrete to continuous, real-time, **hybrid models**
 - from fault diagnosis to **planning**
- Connections
 - with classical **risk analysis** (fault trees, FMEA)
 - with **man-machine interface** issues (observability!)
 - with **epistemic logics** (diagnoser as knowledge agent)
- Keep in touch with reality
 - scalability, relevance to practical needs, tools, integration

References

- On this talk :
Tim Menzies and Charles Pecheur. Verification and Validation and Artificial Intelligence. In: M. Zelkowitz, Ed., Advances in Computers, vol. 65, 2005, Elsevier.
- See also
 - <http://www.info.ucl.ac.be/~pecheur/publi/>
 - <http://www.info.ucl.ac.be/~pecheur/talks/>